



# RA12-100SD(12V100Ah)

RA12-100SD is AGM Deep cycle battery with 10 years floating design life, specially designed for frequent cyclic discharge usage. By using strong grid and specific paste plate, it makes battery have 30% more cyclic life time than standby series. It is applicable for solar energy system, golf cart, electric wheelchair, etc..



## Specification

Cells Per Unit	6
Voltage Per Unit	12
Capacity	100Ah@10hr-rate to 1.75V per cell @25°C
Weight	Approx. 29.0 Kg
Max. Discharge Current	900 A (5 sec)
Internal Resistance	Approx. 4.8 mΩ
Operating Temperature Range	Discharge: -20°C~60°C Charge: 0°C~50°C Storage: -20°C~60°C
Normal Operating Temperature Range	25°C±5°C
Float charging Voltage	13.6 to 13.8 VDC/unit Average at 25°C
Recommended Maximum Charging Current Limit	30A
Equalization and Cycle Service	14.6 to 14.8 VDC/unit Average at 25°C
Self Discharge	RITAR batteries can be stored for more than 6 months at 25°C. Self-discharge ratio less than 3% per month at 25°C. Please charge batteries before using.
Terminal	Terminal F15/F12
Container Material	A.B.S. (UL94-HB) , Flammability resistance of UL94-V1 can be available upon request.



MH28539



G4M20206-0910-E-16



ISO9001:2000 Certificate

## Dimensions

Unit: mm Dimension: 306.5(L)×168.5(W)×210(H)

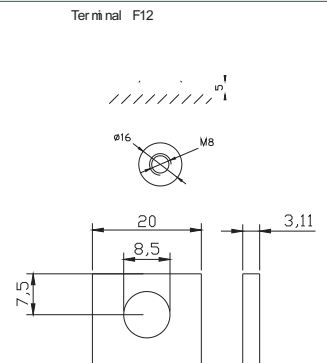
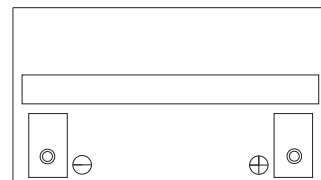
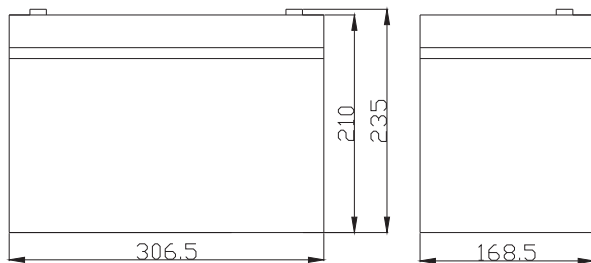

## Constant Current Discharge Characteristics: A (25°C)

F.V/Time	5MIN	10MIN	15MIN	30MIN	1HR	2HR	3HR	4HR	5HR	8HR	10HR	20HR
9.60V	344.7	247.0	179.7	110.4	62.40	35.39	25.06	20.74	16.32	11.92	10.08	5.33
10.0V	335.5	235.0	176.0	108.6	62.11	35.12	24.96	20.64	16.22	11.83	9.99	5.24
10.2V	316.1	226.7	173.3	107.6	61.54	34.84	24.77	20.54	16.13	11.73	9.89	5.14
10.5V	283.9	209.2	165.0	104.9	60.96	34.57	24.67	20.35	15.94	11.63	9.79	5.04
10.8V	256.2	190.8	152.1	100.3	59.52	33.93	24.00	19.87	15.65	11.44	9.70	4.94
11.1V	223.0	170.5	136.4	93.98	56.54	33.38	22.94	18.91	14.98	10.96	9.40	4.65

## Constant Power Discharge Characteristics: W (25°C)

F.V/Time	5MIN	10MIN	15MIN	30MIN	1HR	2HR	3HR	4HR	5HR	8HR	10HR	20HR
9.60V	3592	2626	1934	1246	713.7	418.6	289.2	239.6	188.9	138.4	113.4	59.89
10.0V	3518	2509	1894	1230	710.2	417.0	288.6	239.0	187.8	137.8	112.2	59.30
10.2V	3321	2425	1868	1216	705.0	413.1	286.8	237.9	187.2	136.6	111.6	58.72
10.5V	2991	2241	1781	1188	698.1	409.3	285.1	236.2	185.5	135.5	110.5	58.14
10.8V	2690	2035	1637	1134	680.8	403.3	278.2	229.8	182.6	132.6	109.3	57.56
11.1V	2322	1807	1461	1063	645.1	384.7	264.4	218.9	173.4	127.9	105.8	55.23

All mentioned values are average values.

# RA12-100SD

12V100Ah



## Life characteristics of cyclic use

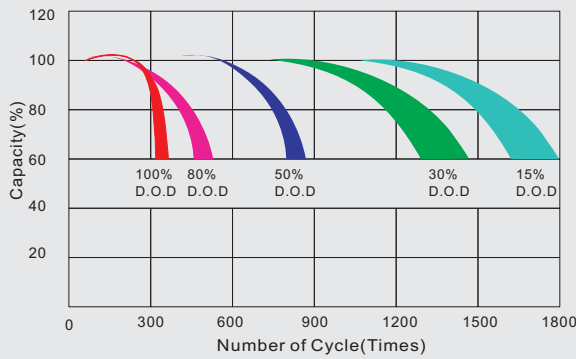

## Storage characteristic

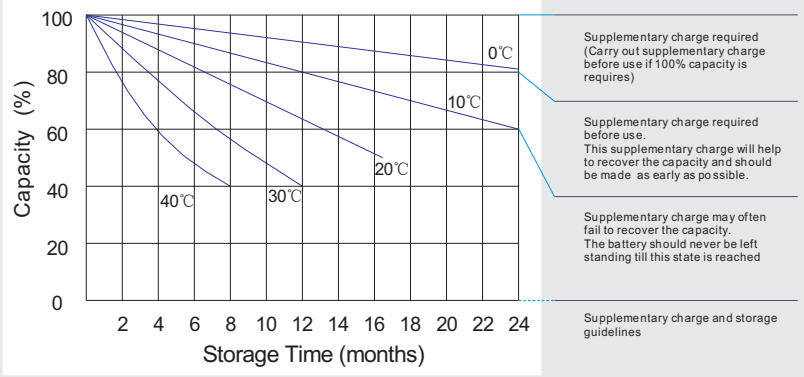

## Charge characteristic Curve for standby use



## Discharge characteristic Curve

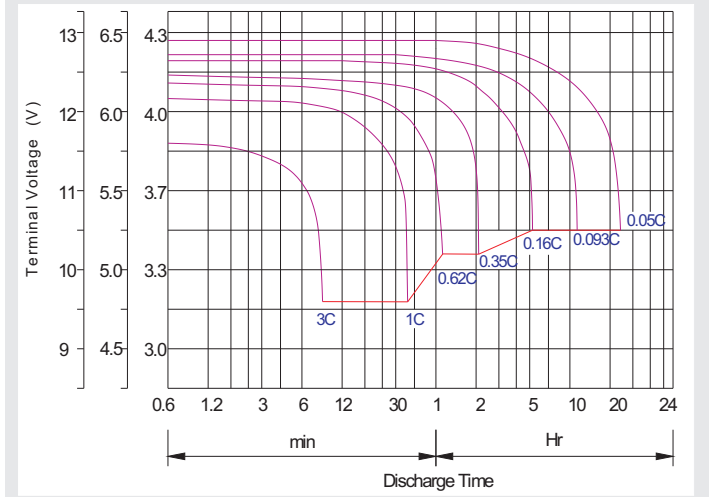

## Capacity Factors With Different Temperature

Battery Type		-20°C	-10°C	0°C	5°C	10°C	20°C	25°C	30°C	40°C	45°C
GEL Battery	6V&12V	50%	70%	83%	85%	90%	98%	100%	102%	104%	105%
	2V	60%	75%	85%	88%	92%	99%	100%	103%	105%	106%
AGM Battery	6V&12V	46%	66%	76%	83%	90%	98%	100%	103%	107%	109%
	2V	55%	70%	80%	85%	92%	99%	100%	104%	108%	110%

## Discharge Current VS. Discharge Voltage

Final Discharge Voltage V/cell	1.75V	1.70V	1.60V
Discharge Current (A)	(A) ≤ 0.2C	0.2C < (A) < 1.0C	(A) ≥ 1.0C

## Maintenance & Cautions

<b>Cycle service</b>
※ Avoid battery over discharge, especially battery series connection use.
※ Charged with recommend voltage, ensure battery can be full recharged.
In general, recharge capacity should be 1.1-1.15 times discharge capacity.
※ Effect of temperature on cycle charge voltage: -4mV/°C/Cell.
※ There are a number of factors that will affect the length of cyclic service.
The most significant are depth of discharge, ambient temperature, discharge rate, and the manner in which the battery is recharged.
Generally speaking, the most important factors is depth of discharge.

**Charge the batteries at least once every six months, if they are stored at 25°C.**

### Charging Method:

Constant Voltage	-0.2Cx2h+2.4~2.45V/Cellx24h, Max. Current 0.3CA
Constant Current	-0.2Cx2h+0.1CAx12h
Fast	-0.2Cx2h+0.3CAx4.0h