

PROJECTA

**POLYCRYSTALLINE
SOLAR PANELS**

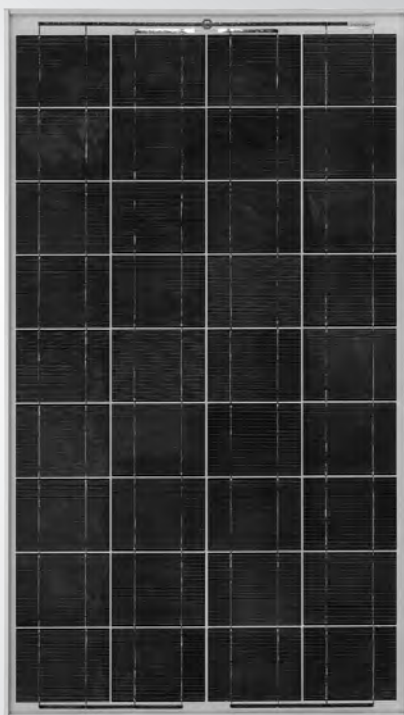

P/No SPP20/40/60/80/120/135

WARNING

- For installations with lead acid batteries, avoid sparks or flames near the batteries and always use proper eye protection.
- Given sufficient light, solar panels always generate energy even when they are disconnected. Accidental 'shorting' of the terminals or wiring can result in sparks causing personal injury or a fire hazard. It is recommended that the front face of the panel(s) are covered with a soft cloth to block incoming light during installation and wiring.
- When connecting panels in series do not exceed 24VDC (Max. 2 panels).
- Do not scratch or bend solar panels.
- Do not disassemble the solar panel frame.
- When mounting solar panels at a height adhere to all relevant safety regulations.
- For fixed installations ground the frame of the solar panel(s) to reduce lightning hazard.
- Do not walk on modules.
- Do not attempt to increase module output by concentrating light on its surface with mirrors.
- Be sure to use components (cables, fuses, etc) with ratings greater than 25% of solar panel/s maximum current ratings.

FEATURES

COMPACT AND POWERFUL

Polycrystalline solar panels are manufactured from a solar cell that is cast from silicon. These cells are more efficient at producing power than an amorphous panel, so the size of the panel is smaller yet produces greater output power.

HEAVY DUTY FRAME

Corrosion resistant frames are constructed to withstand wind speeds in excess of 130 km/h in typical ground mounted applications. The frames are clear anodized and the inner corner connection has a strong mechanical resistance to weather.

TEMPERED LOW IRON GLASS

Clear encapsulated insulation enhances solar cell performance and provides proven weather protection, Tempered low iron glass provides both better impact resistance and better light transmission, allowing the generation of more electricity by reducing the quantity of light that is reflected away from the module.

SPECIFICATIONS

Table 1

	SPP20	SPP40	SPP60	SPP80	SPP120	SPP135
TYPE	Polycrystalline	Polycrystalline	Polycrystalline	Polycrystalline	Polycrystalline	Polycrystalline
RATED POWER	20W	40W	60W	80W	120W	135W
OPEN CIRCUIT VOLTAGES	21V	21V	21V	21V	21V	21V
SHORT CIRCUIT CURRENT	1.25A	2.5A	3.76A	5.04A	7.55A	8.5A
PEAK POWER VOLTAGE	17.5V	17.5V	17.5V	17.5V	17.5V	17.5V
PEAK POWER CURRENT	1.14A	2.28A	3.43A	4.58A	6.86A	7.72A
TEST CONDITIONS	1000W/m ² 25°C	1000W/m ² 25°C	1000W/m ² 25°C	1000W/m ² 25°C	1000W/m ² 25°C	1000W/m ² 25°C

	SPP20	SPP40	SPP60	SPP80	SPP120	SPP135
BATTERY SIZES (1 Panel)	200–750CCA (automotive)	250–500CCA (automotive)	250–650CCA (automotive)	250–900CCA (automotive)	250–1200CCA (automotive)	300–1300CCA (automotive)
	250–800MCA (marine)	250–550MCA (marine)	300–700MCA (marine)	300–1000MCA (marine)	350–1500MCA (marine)	400–2000MCA (marine)
	20–100Ah (deep cycle)	20–70Ah (deep cycle)	20–100Ah (deep cycle)	30–140Ah (deep cycle)	40–200Ah (deep cycle)	50–240Ah (deep cycle)

INSTALLATION

PLACEMENT

Locate the panel in a position where it is exposed to the sun for the majority of the day. For best results use a northern orientation. Make sure that the front side (dark side) of the solar panel faces the sun. Although the panel will function in the horizontal position, for best performance tilt the panel towards the sun especially during the winter months in the southern states. The angle of the tilt should be similar to the angle of the sun so that the panel is perpendicular to the sun rays. Recommended angles for Indonesian, Australian & New Zealand latitudes are shown below:

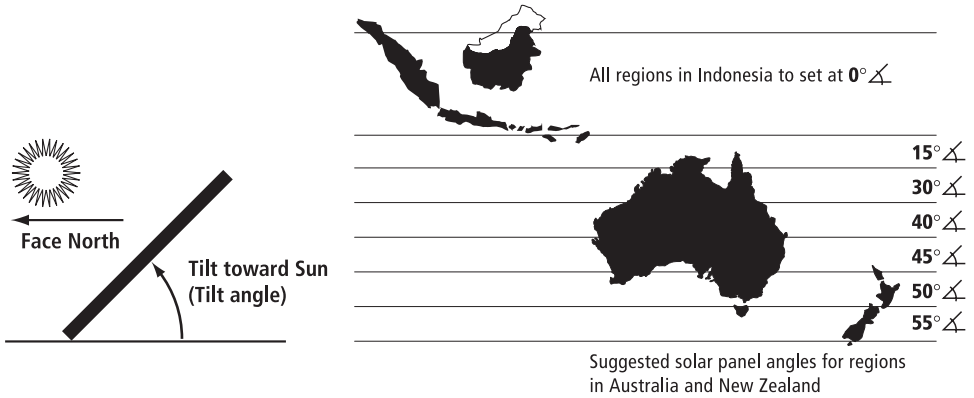

MOUNTING

The panels are supplied with four or eight mounting holes (depending on the model). Use suitable fasteners and mount the panel to a flat surface or mounting frame as per fig. 1, 2 & 3. Ensure the battens or frame does not twist or bend the solar panel's aluminium frame.

FIG 1

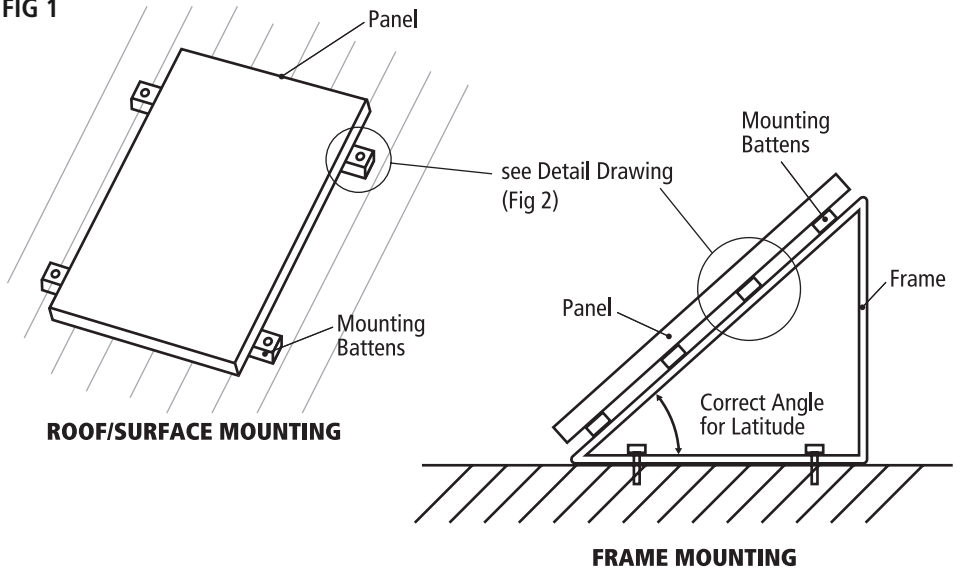

FIG 2

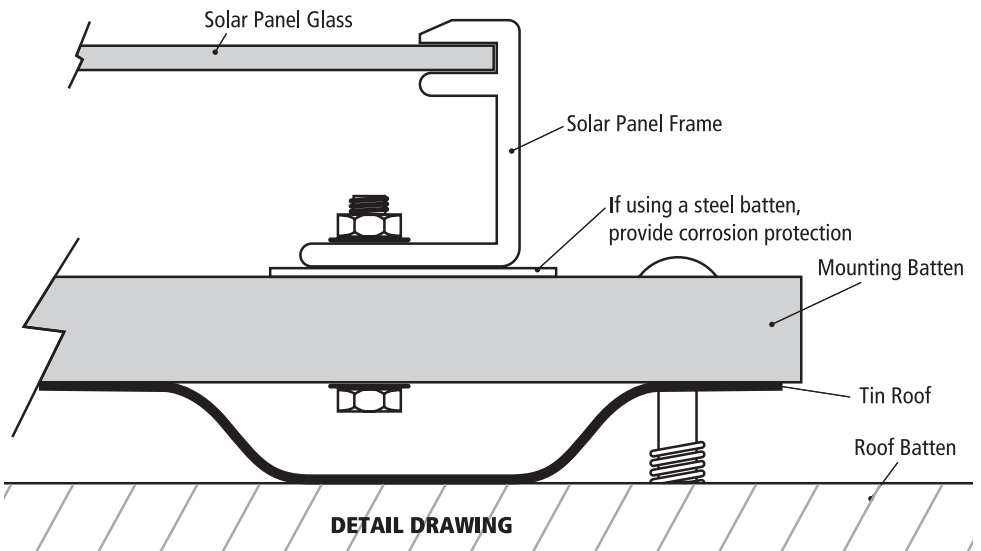
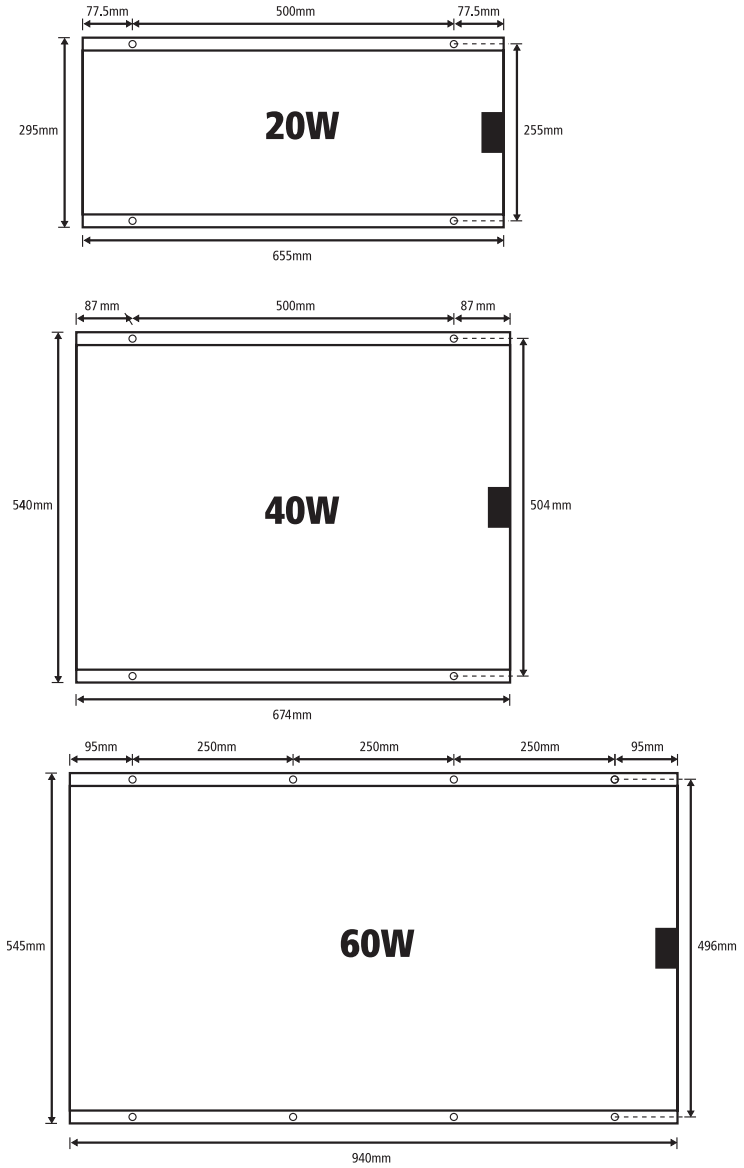
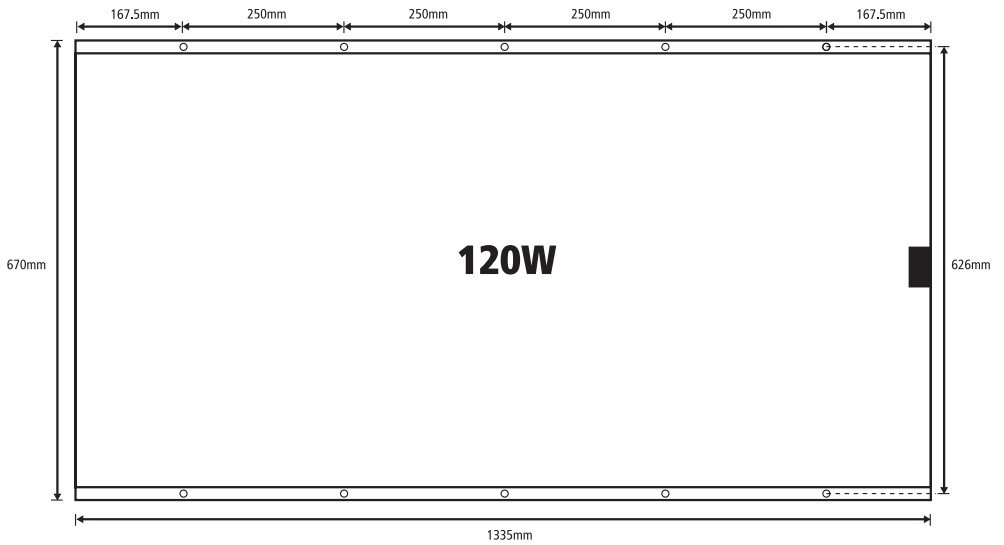
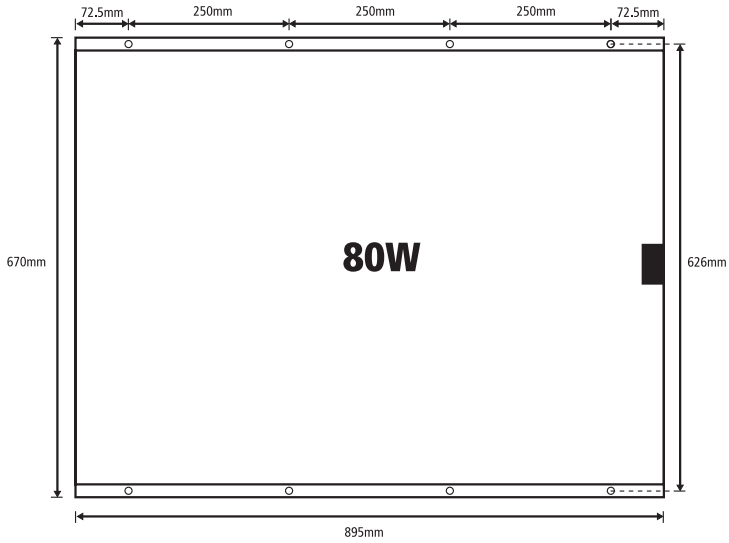

FIG 3



FIXING HOLE DIMENSIONS (NOT DRAWN TO SCALE)



FIXING HOLE DIMENSIONS (NOT DRAWN TO SCALE)

FIG 3 (continued)

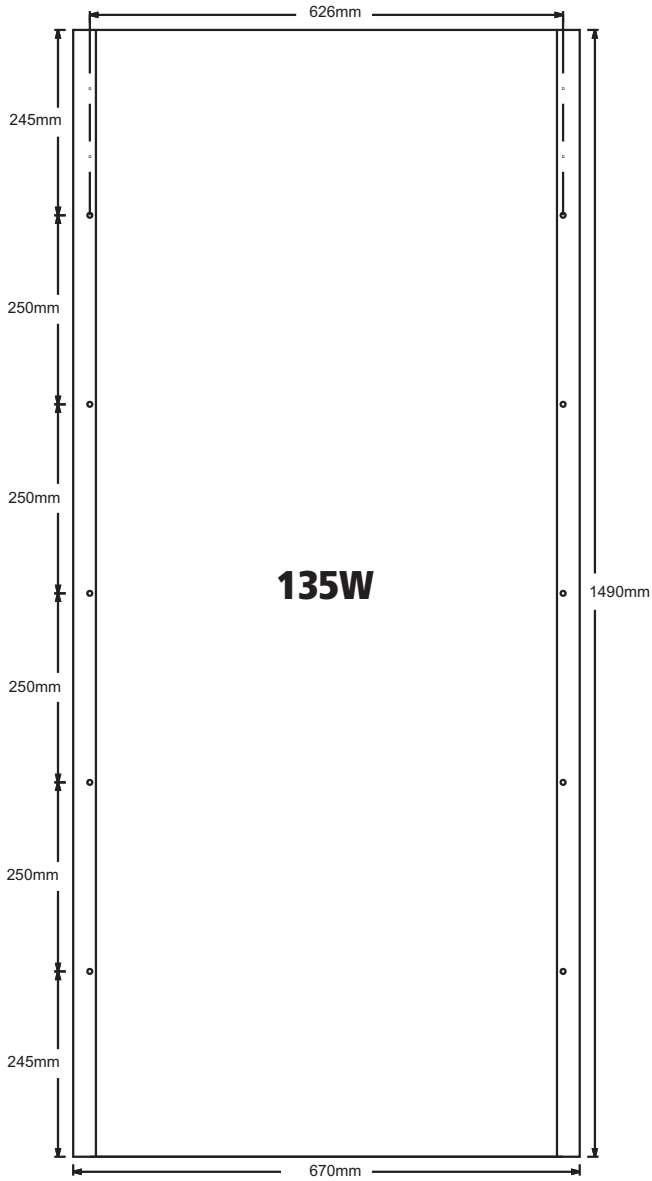

FIXING HOLE DIMENSIONS (NOT DRAWN TO SCALE)

CHARGE CONTROL

Solar panels are most commonly used to charge lead acid batteries. Projecta solar panels are designed to charge 12 VDC batteries. 24VDC batteries can be charged using 2 panels wired in series and using a 24VDC solar charge controller.

For battery charging it is recommended that you use a Solar Charge controller to prevent the battery from being overcharged (damaged) and prevent the battery from discharging (losing power) into the solar panel at night. Solar Charge controllers are connected between the solar panel and the battery.

Projecta 12VDC Solar Charge controllers:

P/No. SC005 – 7 AMP Automatic Solar Charge Controller (suitable) for solar panels up to 80W.

P/No. SC010 – 10 AMP Automatic Solar Charge Controller (suitable) for solar panels up to 120W.

Projecta 12 & 24VDC Solar Charge Controllers:

P/No. SC310 – 10 AMP Automatic Solar Charge Controller (suitable) for solar panels up to 120W.

P/No. SC320 & SC320D – 20 AMP Automatic Solar Charge Controller (suitable) for solar panels up to 240W.

P/No. SC330 – 30 AMP Automatic Solar Charge Controller (suitable) for solar panels up to 360W.

P/No. SC340 – 40 AMP Automatic Solar Charge Controller (suitable) for solar panels up to 480W.

CONNECTING SOLAR PANEL TO BATTERY

Projecta products are covered by a 12 month warranty. Failure to follow the operating instructions may damage the product and will void warranty. Please read these operating instructions carefully before use. For a warranty claim please return unit to the place of purchase with your sales receipt as proof of purchase date.

Single Panel, 12V Installation

You will also need:

- Suitable solar controller
 - Suitable cable. (If solar panel is within 3 metres from the battery use 4mm cable, within 6m use 5mm cable and within 9 metres use 6mm. It is not recommended to run longer than 9m.)
 - 10A Fuse or circuit breaker.
1. Connect a fuse or circuit breaker to the positive terminal of the battery, (As near to the battery as possible) refer to Fig. 4. Leave the fuse out.
 2. Connect a cable from the fuse or circuit breaker to the solar controllers' positive terminal.
 3. Connect a cable from the battery's negative terminal to the solar controller's negative terminal.
 4. Connect the solar panel to the solar controller. Ensure positive to positive and negative to negative. Refer to Figure 5.
 5. Insert fuse.

FIG 4

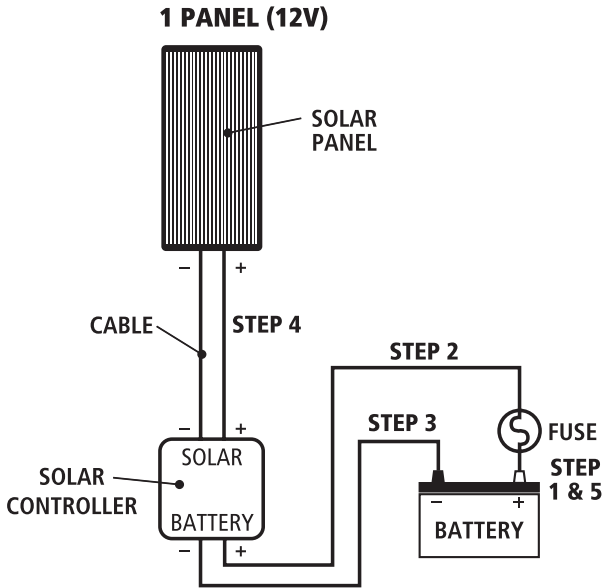
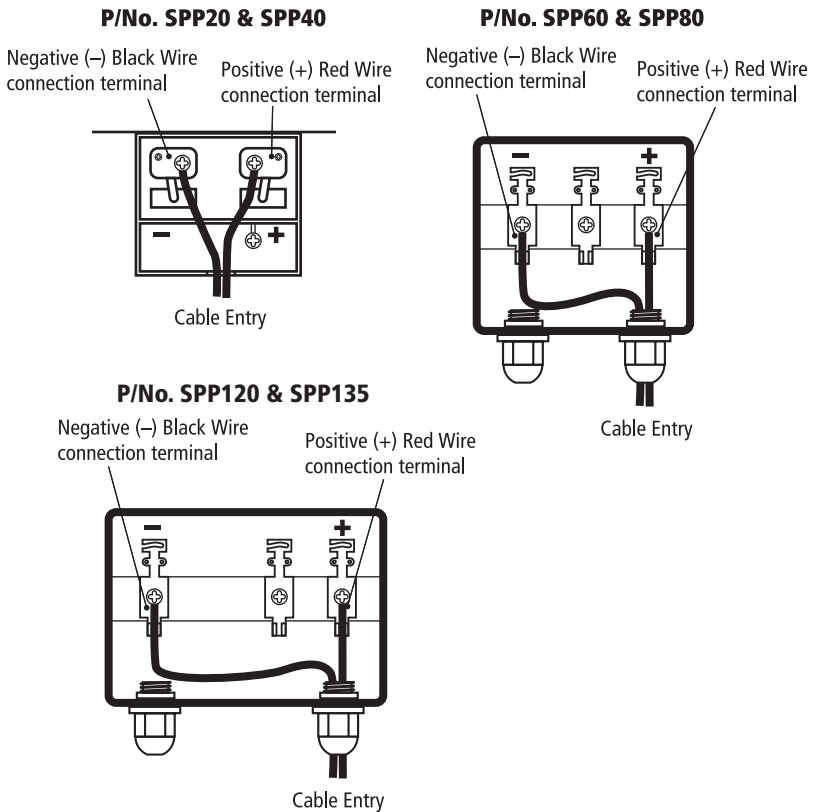

FIG 5



CONNECTING MULTIPLE SOLAR PANELS

Additional solar panels can be connected together. Different configurations produce different voltages and currents. For example: Two panels connected in series, will double the voltage. Two panels connected in parallel will double the current.

Note: When connecting multiple solar panels in arrays always use the same type and size!

Blocking & Bypass Diodes – Shading

Where multiple solar panels are used, diodes are necessary to ensure solar panels perform as efficiently as possible. If one of the solar panels is shaded it will begin to discharge (draw power from the system). To overcome this effect, diodes are placed in the circuit. See Fig. 6 & Fig. 8.

Two Panels in Series 24V Installation

You will also need:

- 24V Solar Controller
 - Suitable cable. (If solar panel is within 3 metres from the battery use 4mm cable, within 6m use 5mm cable and within 9 metres use 6mm. It is not recommended to run longer than 9m.)
 - 10A Fuse or circuit breaker
 - 2 diodes (Projecta P/No. SPPDIODE) required on SPP20 & SPP40 as bypass diodes. Bypass diodes are built in on SPP60, SPP80, SPP120 & SPP135.
1. Connect a fuse or circuit to the positive terminal of the battery bank, (As near to the battery as possible) refer to Fig. 6. Leave the fuse out.
 2. Connect a cable from the fuse or circuit breaker to the solar controllers' positive terminal.
 3. Connect a cable from the battery bank's negative terminal to the solar controller's negative terminal.
 4. (SPP20 & SPP40 Only) Fit one bypass diode per solar panel between the negative and positive terminals inside the solar panel's junction box. Be sure to connect the end of the diode with the white band to the positive terminal. Refer to Fig 7 opposite page.
 5. Connect a cable from Solar Panel No.1's positive terminal to Solar Panel No.2's negative terminal to create a solar panel array.
 6. Connect a cable from the solar array's negative terminal to the solar controller's negative terminal.
 7. Connect a cable from the solar array's positive terminal to the solar controller's positive terminal.
 8. Insert fuse.

FIG 6

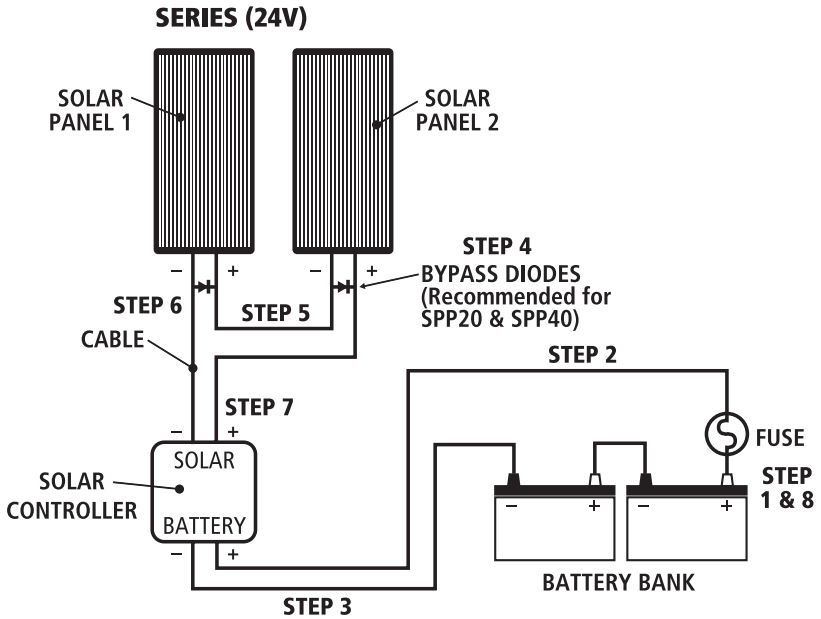
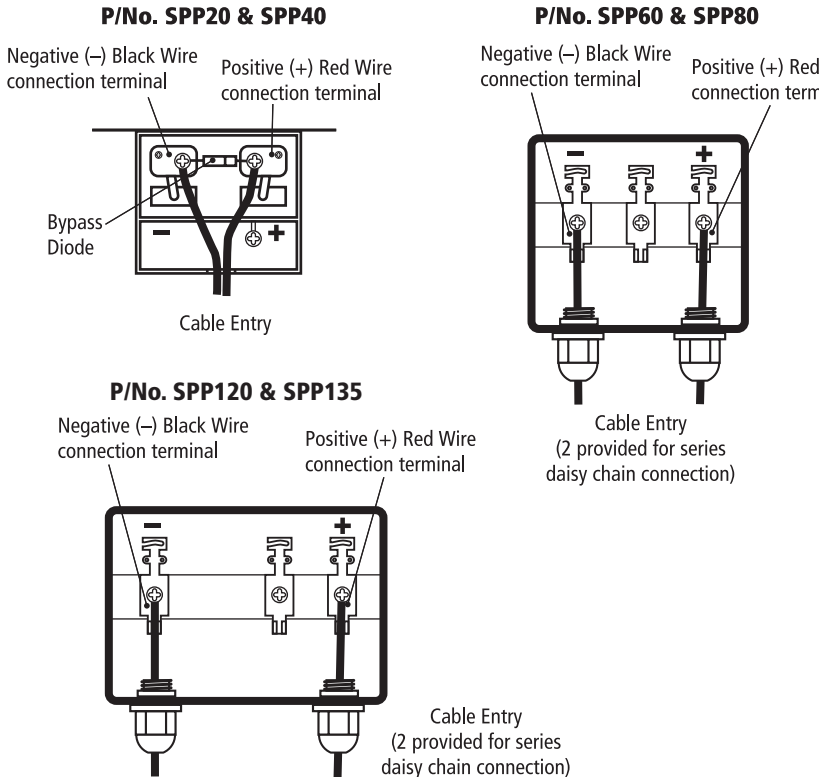

FIG 7



Two Panels in Parallel, 12V Installation

You will also need:

- Suitable solar controller
 - Suitable cable (See table 2 for recommended cable sizes)
 - Correct rated fuse or circuit breaker
 - 2 diodes (Projecta P/No. SPPDIODE suitable for up to 80W) used as blocking diodes.
1. Connect a fuse or circuit breaker to the positive terminal of the battery, (As near to the battery as possible) refer to Fig. 8. Leave the fuse out.
 2. Connect a cable from the fuse or circuit breaker to the solar controllers' positive terminal.
 3. Connect a cable from the battery's negative terminal to the solar controller's negative terminal.
 4. Connect one blocking diode per solar panel. Be sure to connect the end of the diode with the white band to the extra post and the unmarked end to the positive (+) terminal. Note: The SPP60, SPP80, SPP120 & SPP135 do not have an extra post and will have to be connected directly to the cable. See Fig. 9.
 5. Connect both solar panels to the solar controller. Ensure positive to positive and negative to negative. Refer to Figure 8.
 6. Insert fuse.

Note: More than two solar panels can be added in parallel by simply repeating steps 4 and 5. Depending on the number of Solar panels added choose a solar controller, fuse and cabling between the battery and solar controller that will handle the increased current.

Table 2 – Recommended Cable Sizes

Cable distance (meters)	Solar Panel SPP20 x 2 (Total 40W, 2.28A)	Solar Panel SPP40 x 2 (Total 80W, 4.56A)	Solar Panel SPP60 x 2 (Total 120W, 6.86A)	Solar Panel SPP80 x 2 (Total 160W, 9.16A)	Solar Panel SPP120 x 2 (Total 240W, 13.72A)	Solar Panel SPP135 x 2 (Total 270W, 15.44A)
3m	3mm	3mm	4mm	4mm	5mm	5mm
6m	3mm	4mm	5mm	6mm	8mm ² or 8 B&S	8mm ² or 8 B&S
9m	4mm	4mm	6mm	8mm ² or 8 B&S	8mm ² or 8 B&S	8mm ² or 8 B&S

FIG 8

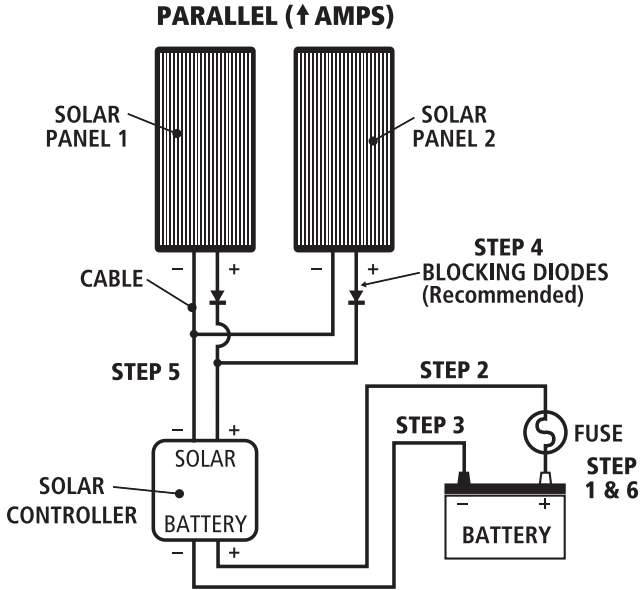
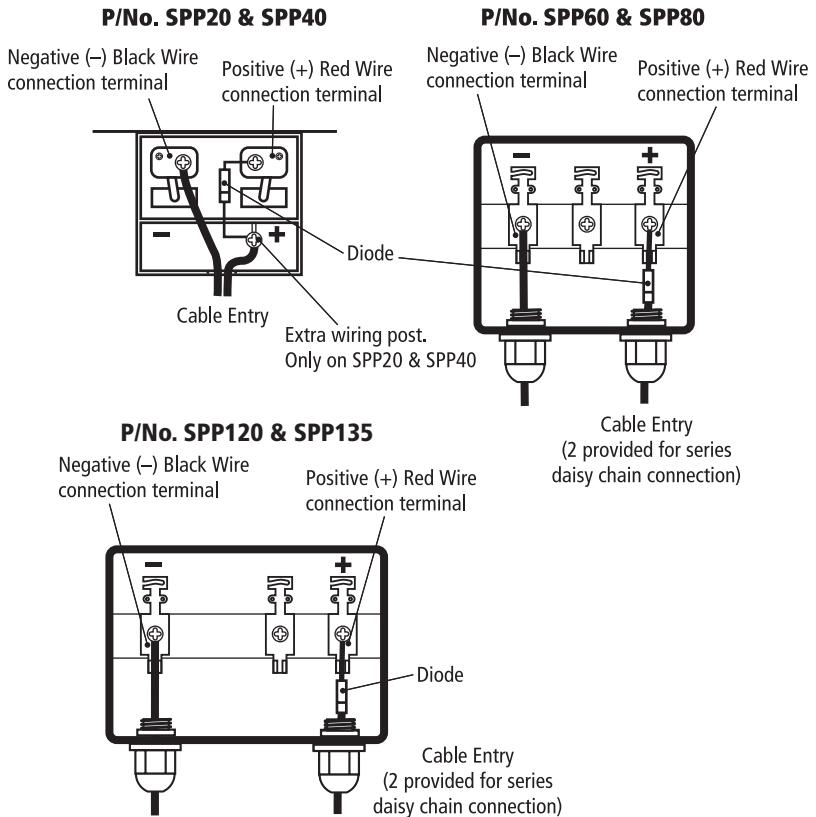

FIG 9



Four Panels in Series & Parallel, 24V Installation

You will also need:

- 24V Solar Controller
 - Suitable cable. (see Table 3 for recommended cable sizes)
 - Correct rated fuse or circuit breaker
 - 2 diodes for blocking (Projecta P/No. SPPDIODE suitable for up to 80W) plus 4 more bypass diodes if using SPP20 or SPP40. Bypass diodes are not necessary using the SPP60, SPP80, SPP120 & SPP135 as they are already built in.
1. Connect a fuse or circuit breaker to the positive terminal of the battery, (As near to the battery as possible) refer to Fig. 10. Leave the fuse out.
 2. Connect a cable from the fuse or circuit breaker to the solar controllers' positive terminal.
 3. Connect a cable from the battery's negative terminal to the solar controller's negative terminal.
 4. (SPP20 & SPP40 Only) Fit one bypass diode per solar panel between the negative and positive terminals inside the solar panel's junction box. Be sure to connect the end of the diode with the white band to the positive terminal. Refer to Fig 11.
 5. Connect blocking diode to solar Panel 2 and 4. Be sure to connect the end of the diode with the white band to the extra post and the unmarked end to the positive (+) terminal. Note: The SPP60, SPP80, SPP120 & SPP135 do not have an extra post and will have to be connected directly to the cable. See Fig. 11.
 6. Connect the cable from Solar Panel No.1's positive terminal to Solar Panel No.2's negative terminal to create a solar panel array.
 7. Connect the cable from Solar Panel No.3's positive terminal to Solar Panel No.4's negative terminal to create a second solar panel array.
 8. Connect cables from all of the solar array's negative terminals to the solar controller's negative terminal.
 9. Connect cables from all of the solar array's positive terminals to the solar controller's positive terminal.
 10. Insert fuse.

Table 3 – Recommended Cable Sizes

Cable distance (meters)	Solar Panel SPP20 x 4 (24V, 2.28A)	Solar Panel SPP40 x 4 (24V, 4.56A)	Solar Panel SPP60 x 4 (24V, 6.86A)	Solar Panel SPP80 x 4 (24V, 9.16A)	Solar Panel SPP120 x 4 (24V, 13.72A)	Solar Panel SPP135 x 4 (24V, 15.44A)
3m	3mm	3mm	4mm	4mm	5mm	5mm
6m	3mm	4mm	5mm	6mm	8mm ² or 8 B&S	8mm ² or 8 B&S
9m	4mm	4mm	6mm	8mm ² or 8 B&S	8mm ² or 8 B&S	8mm ² or 8 B&S

FIG 10

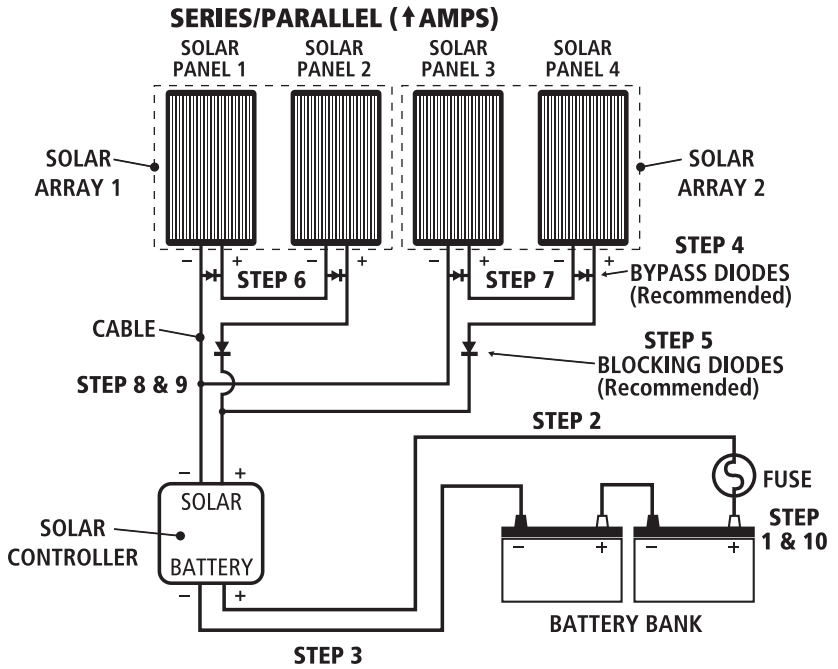
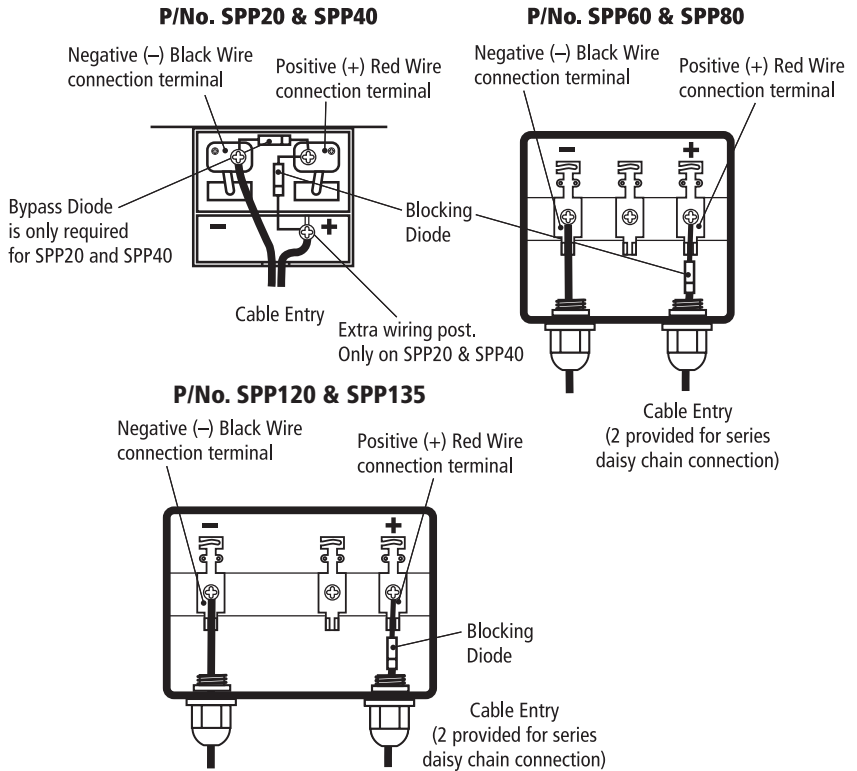

FIG 11



MAINTENANCE

Periodically inspect the electrical connections and panel mounting bolts. Make sure they are all tight and free from corrosion. If necessary clean the surface of the solar panels with a soft damp cloth. Mild detergent can also be used. Any dirt or residue on the glass may effect performance.

FREQUENTLY ASKED QUESTIONS

Q. Can the solar panel be mounted on a flat roof or wall?

A. Yes. It is fine to mount the panel on a horizontal surface such as a roof or on a vertical surface like a wall as long as the panel receives full sun for a reasonable period of the day. You will however gain 25% performance if the panel is tilted toward the sun and faced in a northerly direction, since this enables the maximum amount of solar energy to reach the panel.

Q. What appliances can I run on the solar panel?

A. Solar panels gain all their energy from the sun and are therefore limited in their ability to operate 12VDC appliances directly. Although they may run very small appliances it is more common to connect the solar panel and appliance to a battery. This method is much more effective, provides a stable voltage and allows the appliance to continue to operate even if the panel is shaded.

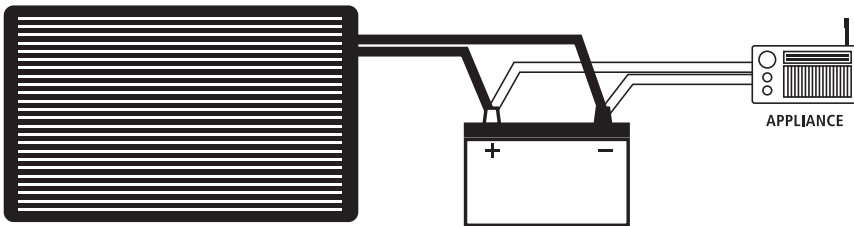

Q. Can I run more than one solar panel?

A. It is possible to run multiple solar panels for higher voltage applications or for more power:

1. Placing 2 solar panels in 'Series' will make them suitable for use on 24VDC battery systems or vehicles.
2. Placing 2 or more panels in 'Parallel' will still make them suitable for 12VDC use but will provide twice as much power (current). Refer to the section "**Connecting Multiple Solar Panels**".

Q. Will the solar panel charge my flat battery & how long will it take?

- A. 1. The SPP20 is designed for ‘topping up’ and maintaining batteries. Given sufficient time it will put some charge back into the battery.
 2. The SPP40, SPP60, SPP80, SPP120 & SPP135 will charge a battery. See table below for recommended charge times.

Recommended charge times for different solar panels

	SPP20	SPP40	SPP60	SPP80	SPP120	SPP135
Automotive	200–750 CCA	250–500 CCA	250–650 CCA	250–900 CCA	250–1200 CCA	300–1300 CCA
Marine	250–800 MCA	250–550 MCA	300–700 MCA	300–1000 MCA	350–1500 MCA	400–2000 MCA
Deep Cycle	20–100 Ah	20–70 Ah	20–100 Ah	30–140 Ah	40–200 Ah	50–240 Ah
Charging times	Maintenance	10–30 Hours	8–35 Hours	7–35 Hours	7–35 Hours	7–35 Hours

Q. I am going on a 4WD trip. How many solar panels will I need?

- A. It really comes down to how many appliances are drawing power from your battery.
 The number of solar panels required should be based on how much power is used over a 24 hour period.

For example: Most people when they go away would run a Fridge, and a couple of lights to cook with etc. We need to work out how much power would be used in a day.

Energy consumption per day

Appliance	Current use/hour (Ah)	Total time of use/day (Hours)	Total Current per day (Amps)
Fridge	1.5	24	36
Lights	3	3	9
Grand total			45

So we need to size a solar system that can produce around 45 Amps per day. If we say we get around 10 hours of solar energy from the panels per day (for summer months). We can then calculate what size and how many panels we need.

$$45 \text{ amps} \div 10 \text{ hours} = 4.5 \text{ Amps per hour}$$

So two SPP40 solar panels wired in parallel or one SPP80 to produce 4.6 Amps an hour should be more than enough. You might find that during cloudy weather you will have to charge the battery by running your car for half an hour every second or third day

WARRANTY STATEMENT

Applicable only to product sold in Australia

Brown & Watson International Pty Ltd of 1500 Ferntree Gully Road, Knoxfield, Vic., telephone (03) 9730 6000, fax (03) 9730 6050, warrants that all products described in its current catalogue (save and except for all bulbs and lenses whether made of glass or some other substance) will under normal use and service be free of failures in material and workmanship for a period of one (1) year (unless this period has been extended as indicated elsewhere) from the date of the original purchase by the consumer as marked on the invoice. This warranty does not cover ordinary wear and tear, abuse, alteration of products or damage caused by the consumer. Projecta solar panels are covered by a 1 year warranty for materials and workmanship and a 20 year warranty for at least 80% power output.

To make a warranty claim the consumer must deliver the product at their cost to the original place of purchase or to any other place which may be nominated by either BWI or the retailer from where the product was bought in order that a warranty assessment may be performed. The consumer must also deliver the original invoice evidencing the date and place of purchase together with an explanation in writing as to the nature of the claim.

In the event that the claim is determined to be for a minor failure of the product then BWI reserves the right to repair or replace it at its discretion. In the event that a major failure is determined the consumer will be entitled to a replacement or a refund as well as compensation for any other reasonably foreseeable loss or damage.

This warranty is in addition to any other rights or remedies that the consumer may have under State or Federal legislation.

IMPORTANT NOTE

Our goods come with guarantees that cannot be excluded under the Australian Consumer Law. You are entitled to a replacement or refund for a major failure and compensation for any other reasonably foreseeable loss or damage. You are also entitled to have the goods repaired or replaced if the goods fail to be of acceptable quality and the failure does not amount to a major failure.

Distributed by

AUSTRALIA

Brown & Watson International Pty Ltd

Knoxfield, Victoria 3180

Telephone (03) 9730 6000

Facsimile (03) 9730 6050

National Toll Free 1800 113 443

NEW ZEALAND

Narva New Zealand Ltd

22–24 Olive Road

PO Box 12556 Penrose

Auckland, New Zealand

Telephone (09) 525 4575

Facsimile (09) 579 1192